

No.	Part	部件	Material	Q'TY
1	Body	阀体	U-PVC,C-PVC,PP	1
2	Ball	球	U-PVC,C-PVC,PP	1
3	Carrier O-Ring	调整座密封环	EPDM,FPM	1
4	Seal Carrier	调整座	U-PVC,C-PVC,PP	1
5	Union	由令锁母	U-PVC,C-PVC,PP	2
6	End Connector	接管	U-PVC,C-PVC,PP	2
7	Seal Seat	阀座	PTFE	2
8	Dampener Seal	阀座支撑密封环	EPDM,FPM	2
9	End Connestor O-Ring	接管密封环	EPDM,FPM	2
10	Stem O-Ring	阀杆密封环	EPDM,FPM	2
11	Stem	阀杆	U-PVC,C-PVC,PP	1
14	Mounting Clamp	支架	PVC-M,SUS304	1
15	Actuator Coupling Bush	执行器联轴器	PVC-M+SUS304	1
16	Bolt	螺栓	SUS 304	4

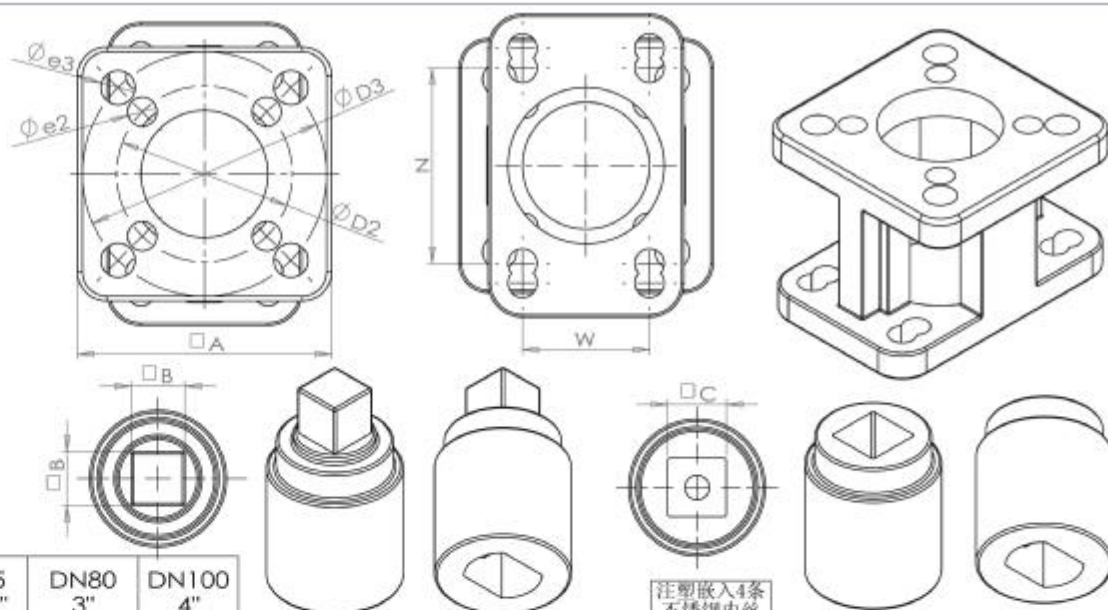

Size	DN15 1/2"	DN20 3/4"	DN25 1"	DN32 1-1/4"	DN40 1-1/2"	DN50 2"	DN65 2-1/2"	DN80 3"	DN100 4"
d	13	18	23	30	38	49	64	77	98
DIN d1	20	25	32	40	50	63	75	90	110
JIS d1	22	26	32	38	48	60	76	89	114
ANSI d1	21.34	26.67	33.4	42.16	48.26	60.28	73.03	88.9	114.3
BS d1	21.2	26.6	33.4	42.1	48.1	60.2	73.2	88.7	114.1
D	56	64	73	88	103	122	156	184	218
D1	31	36	47	56	65	80	94	110	134
D2-e2	36-6F03	36-6F03	36-6F03	36-6F03	50-7F05	50-7F05	70-9F07	70-9F07	70-9F07
D3-e3	50-7F05	50-7F05	50-7F05	50-7F05	70-9F07	70-9F07	102-11 F10	102-11 F10	102-11 F10
A	54	54	54	54	72	72	98	98	98
B	9	9	9,11	11,14	11,14	14,17	14,17	17,22	17,22
C	--	--	12	12	12	12	12,15	12,15,23	15,23
L	120	128	144	158	182	209	246	290	342
L1	23	25	28	32	37	42	45	55	65
H	95	101	113	128	151	171	220	251	296
H3	29.5	33.5	39	47	54	65	82	96	114
H4	28	30	34	41	49	58	68	84	102
H5	7	7	7	7	7.5	7.5	10	10	10
H6	12	12	12,14	14,17	14,17	17,20	17,20	20,25	20,25
H7	--	--	14	14	14	14	14,17	14,17,25	17,25
W	20	20	26	26	32	32	44	44	50
N	28	32	40	48	58	64	84	84	108
M*S	5*12	5*12	5*12	5*12	6*12	6*12	8*14	8*14	8*14

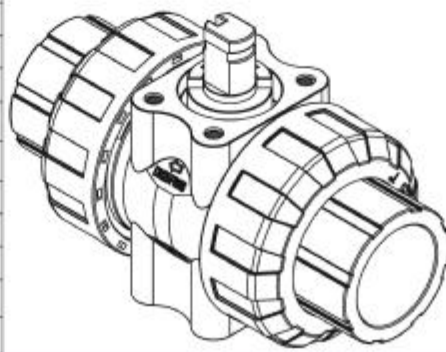

双由令球阀结构图
附加执行器支架和联轴器